

MATERIAL GUIDE ROLLER SETS



Ⓛ type GBSR is shown in the graph.

Drawing: GBSR (R type)

GBSR (R type)
GBSL (L type)

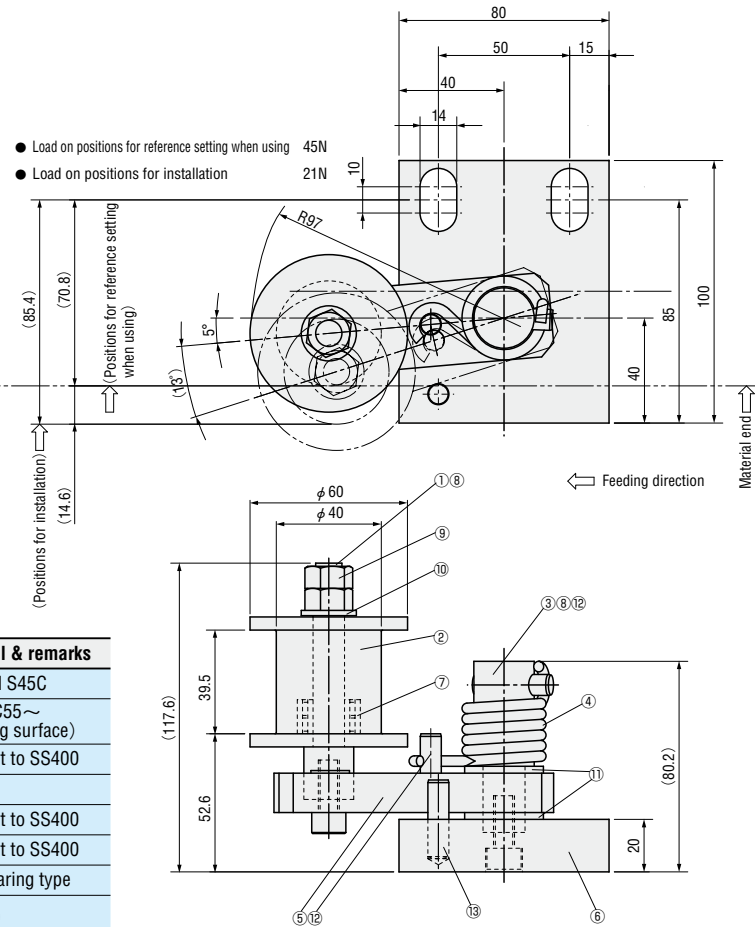

GBSR (L) components list

No.	Name	Qty.	Material & remarks
①	Roller dowel pin	1	Tempered S45C
②	Guide roller	1	40Cr HRC55~ (operating surface)
③	Arm dowel pin	1	Equivalent to SS400
④	Spring	1	65Mn
⑤	Roller arm	1	Equivalent to SS400
⑥	Roller base	1	Equivalent to SS400
⑦	Bearing	1	Roller Bearing type
⑧	Hexagon socket head cap bolt	2	M8 × 20
⑨	Hexagon nut	2	M10
⑩	Washer	1	For M10
⑪	Washer	2	For M16
⑫	Dowel pin	2	φ 8×30
⑬	Dowel pin with female thread	1	φ 8×30

Order **GBSR**

Days to Ship **Quotation**

Price **Quotation**



GBSS

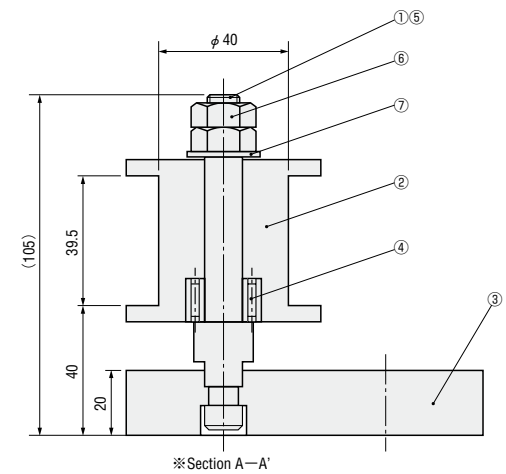
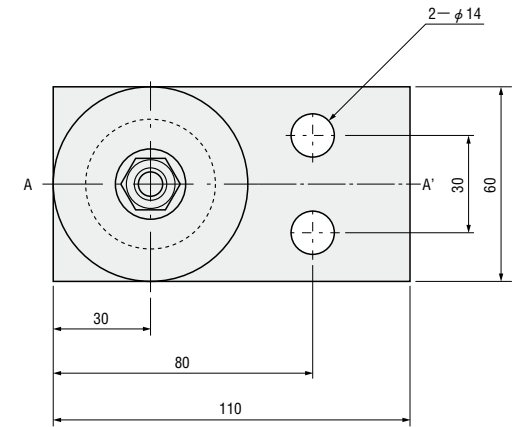

GBSS components list

No.	Name	Qty.	Material & remarks
①	Roller dowel pin	1	Tempered S45C
②	Guide roller	1	40Cr HRC55~ (operating surface)
③	Roller base	1	Equivalent to SS400
④	Bearing	1	Needle type
⑤	Hexagon socket head cap bolt	1	M8 × 20
⑥	Hexagon nut	2	For M10
⑦	Washer	1	For M16

Order **GBSS**

Days to Ship **Quotation**

Price **Quotation**

ex Example

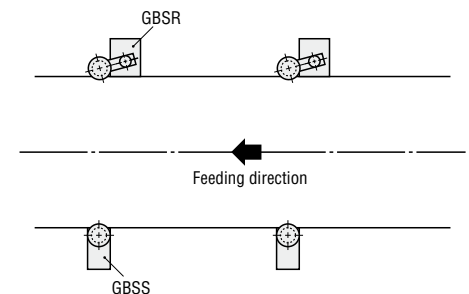

CONVEYANCE COMPONENTS FOR AUTOMOTIVE DIES