

BAFFLE BOARDS

— TAPERED THREAD PLUG TYPE —

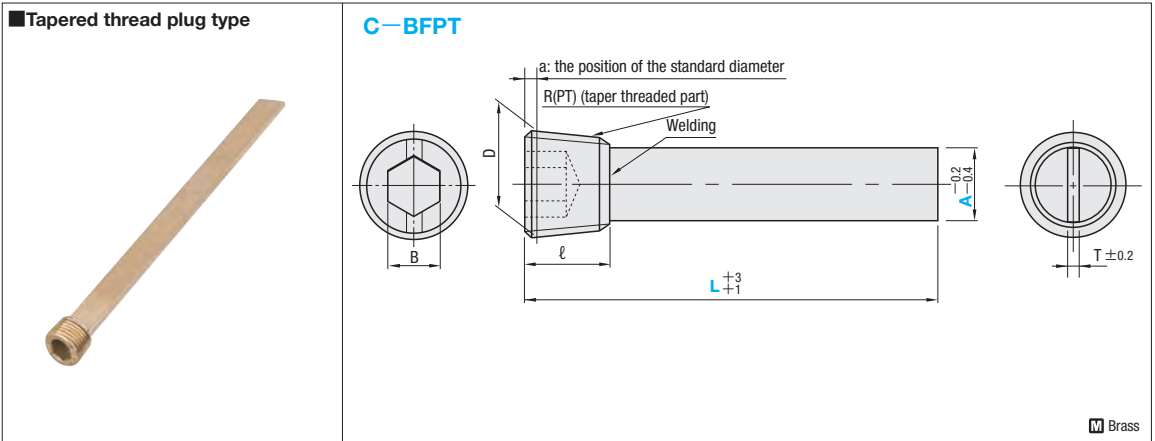

D	a	Number of threads	Pitch	ℓ	B	R(PT)	T	Part No.		L
								Type	A	
13.1	0.7	19	1.34	8.9	6	1/4	2.5	C-BFPT	10	50 100 150
16.6				10	8	3/8			12	
20.8		12	10	1/2	14					
26.4	14	1.81	14	14	3/4	3.2	23.5		50 100 150 200	

⚠ The diameter of the water hole installing C-BFPT should be based on $(A + 0.5 \sim 2)$ mm. ⚠ Discoloration may occur at the welding position.



Order

Part No. — L
C-BFPT 10 — 100



Days to Ship



Stock



Price

Order / Quote:
WOS: <https://in.misumi-ec.com/>
TEL:+91-124-468-8800 E-mail:cs@misumi.co.in



Example

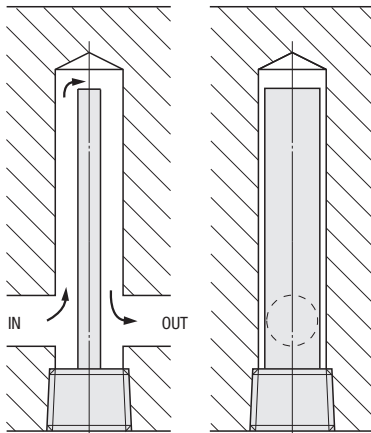

• Processing example of baffle boards

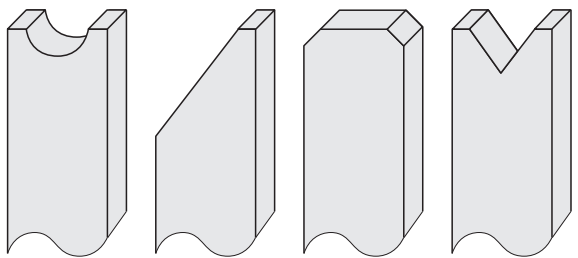

R-cut

Bevel

Chamfer

V-cut

• The position of the baffle board in the direction of rotation should be wrapped with sealing tape or the like to adjust the tightening.