

EARLY RETURN UNITS FOR EJECTOR PLATE

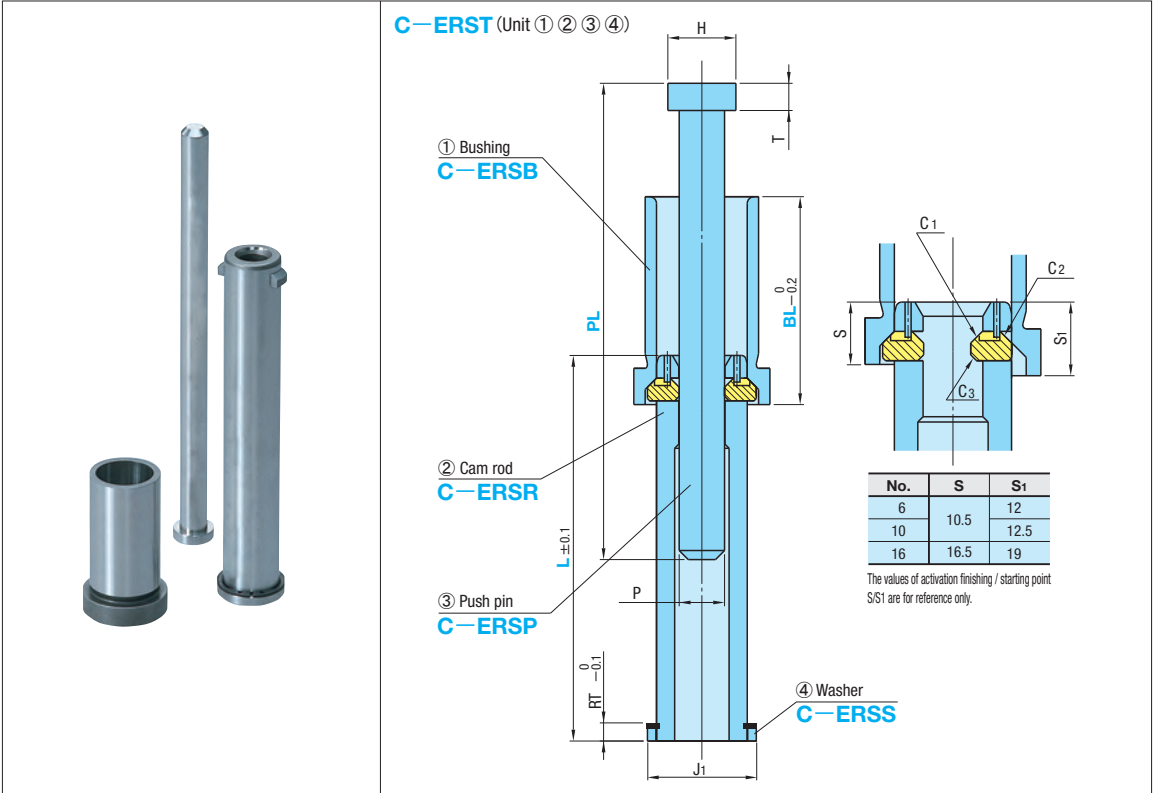

—Components—

① Bushing **C-ERSB**

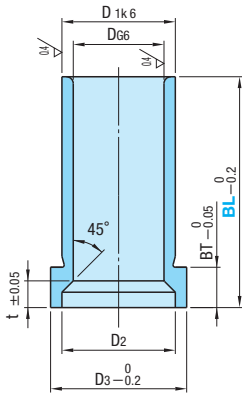

② Cam rod **C-ERSR**

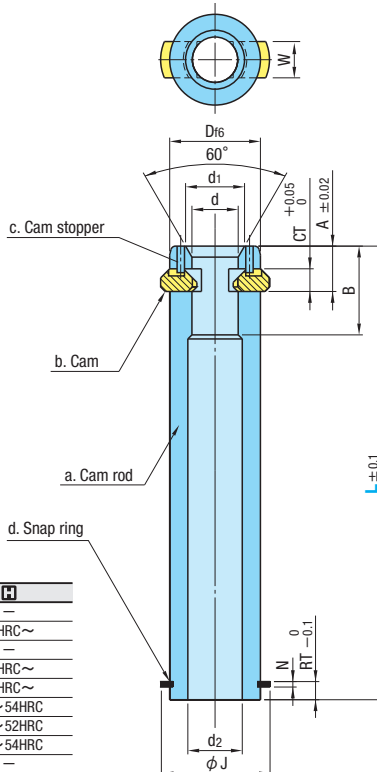

③ Push pin **C-ERSP**

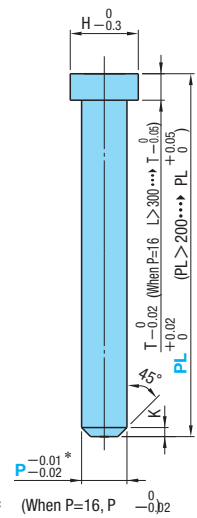

④ Washer **C-ERSS**

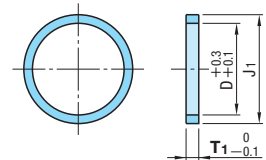

No.	Part No.	Product name	M	H
①②③④	C-ERST	Unit	-	-
①	C-ERSB	Bushing	SUJ2	58HRC~
	C-ERSR	Cam rod	-	-
	a	Cam rod	SUJ2	58HRC~
	b	Cam	SKD11	58HRC~
	c	Cam stopper	SKD61	50~54HRC
②	d	Snap ring	Steel spring	45~52HRC
	C-ERSP	Push pin	SKD61	50~54HRC
④	C-ERSS	Washer	S45C	-