

SIDE STRAIGHT BLOCK SETS

— COMPACT TYPE —

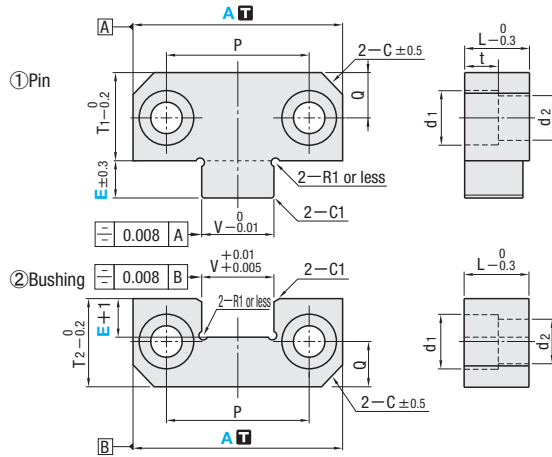

Group	Part No.	T		V dimension symmetry against A/B plane	M	□	
		① Pin	② Bushing				
Precision	C—TSSBT	0 -0.01	+0.01 +0.005	A<30 ... 0 A≥30 ... 0.01 0.02	0.008 or less	YK30 equivalent	56HRC~



V	T ₁	T ₂	C	Bolt Hole				Installation bolts	L	t	Part No.		
				P	Q	d ₁	d ₂				Type	A	E
12	22	22	5	22	7	11	7	M6	13	8	C—TSSBT	38	8
17	21.5	21.5	5	34	11	11	7		16			50	8.5
25	36	36	8	50	18	17	11	M10	19	12		75	14
35	45	45	10	70	22	17	11		19			100	20
45	45	45	10	84	22	17	11		25			125	20

Order —
C—TSSBT 38 — 8

Days to Ship

Price **Order / Quote:**
WOS: <https://in.misumi-ec.com/>
TEL:+91-124-468-8800 E-mail:cs@misumi.co.in

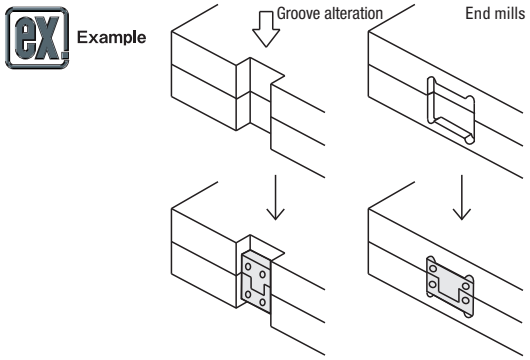

■ Features

- It is suitable for molds with thinner plates and saves installation space.
- It is capable of preventing wear and damage in core pins since it can be positioned before core pins and such are inlaid on cavity.
- Positioning is easily performed by simultaneously processing plates in piles (refers to drawing below)
- Use precision leader pins since clearance is fairly small.

■ Usage

- Contacting the pin and bushing when mold is closed may cause damage. Please leave a clearance of about 1mm on PL.

E	S (Effective length max.)
8	5.5
8.5	6
10	7.5
14	11.5
20	16.0

