

SUPPORT PINS

—PLAIN TYPE • OIL GROOVE TYPE—

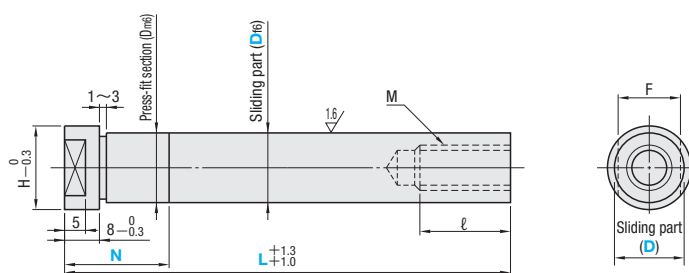

C—SPP (Plain type)



⚠ A center hole may remain on one or both ends.
 ⚠ Designate N=8 when press-fit processing is not required.
 ⚠ Heat treatment colors sometimes remain on the head.
 ⚠ The operating temperature is below 80 °C.

M 20Cr
H 56HRC~
 (Depth of more than 0.8 mm)



C—SPP—OC (Oil groove type)

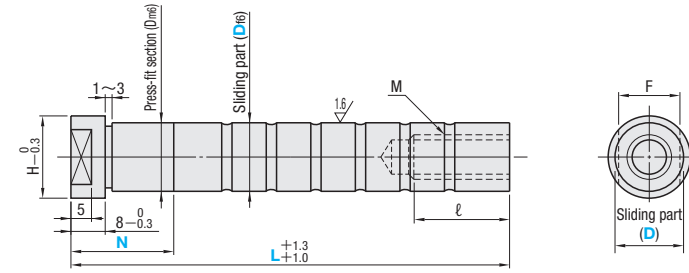

⚠ There may be a center hole on the end.
 ⚠ Designate N=8 when press-fit processing is not required.
 ⚠ Heat treatment colors sometimes remain on the head.
 ⚠ The oil groove sometimes has no heat treatment colors.
 ⚠ The operating temperature is below 80 °C.

M 20Cr
H 56HRC~
 (Depth of more than 0.8 mm)

Sliding part Df6		Press-fit section Dm6		F	H	M (Coarse thread)		Part No.		L	N	
						M×Pitch	ℓ	Type	D		5mm increments	C—SPP
20		20		19	23	M12×1.75	24	C—SPP (No oil groove type)	20	90~300	8~60	8~30
25	-0.020 -0.033	25	+0.021 +0.008	22	28	M16×2.0	32		25	100~300		8~40
30		30		29	35				30	150~350		8~50
35	-0.025 -0.041	35	+0.025 +0.009	32	40				35	150~350		
								C—SPP—OC (With oil groove type)				



Order

Part No.		—	L	—	N
C—SPP	25	—	190	—	N50
C—SPP—OC	25	—	190	—	N30



Days to Ship

•C—SPP	•C—SPP—OC
12 Days	15 Days



Price

Order / Quote:
 WOS: <https://in.misumi-ec.com/>
 TEL:+91-124-468-8800 E-mail:cs@misumi.co.in