

CENTERING SLEEVE

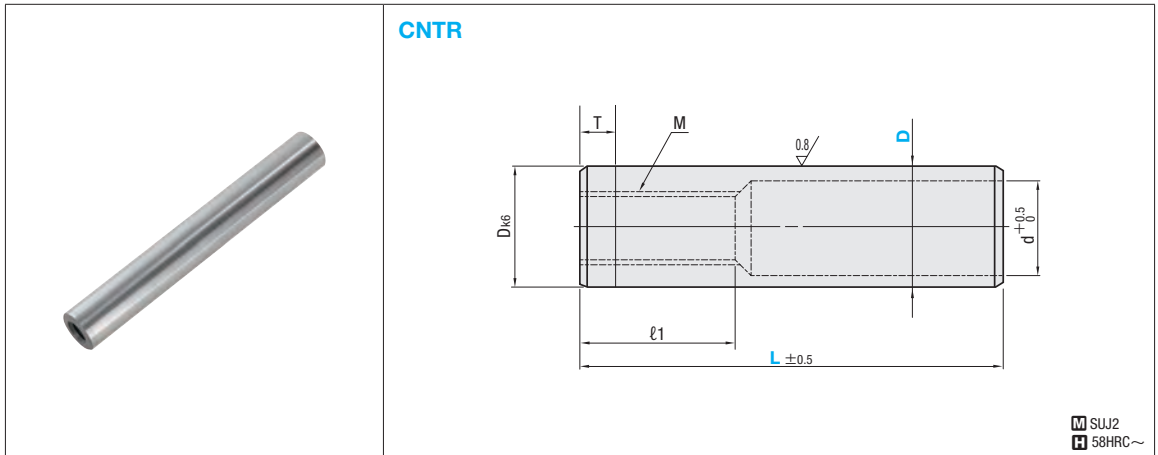

SUJ2
 58HRC~

T	ℓ1	M	d	Part No.		L
				Type	D	
2.5	8.8	M8	11	CNTR	14	20 30 40 50 60 70 80 100
	11.2	M12	16		20	30 40 50 60 80 100 120 140 160
	15.2		26		30 40 50 60 80 100 120 140 160 180	
	16.1		30		40 50 60 80 100 120 140 160 180 200 220 240	
4	20.8	M12	33	42	40 60 80 100 120 140 160 180 200 220 240 260 280 300	
	22.9		54	60 80 120 160 180 200 220 240 260 280 300 320		
	25.2		66	80 120 160 180 200 220 240 260 280 300 320		

■ Tolerance for D and DK

D	D k6	
	g6	f6
14	-0.006 -0.017	+0.012 +0.001
20	-0.007 -0.020	+0.015 +0.002
26		
30	-0.009	+0.018
42	-0.025	+0.002
54	-0.030 -0.049	+0.021 +0.002
66		



Order

Part No. — L
CNTR30 — **160**



Days to Ship

15 Days



Price

Order / Quote:
 WOS: <https://in.misumi-ec.com/>
 TEL:+91-124-468-8800 E-mail:cs@misumi.co.in



Example

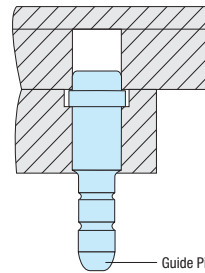

Guide Pillar (D—GPM00) P.155

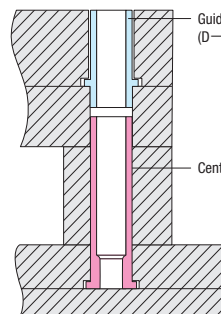

Guide Bushing (D—GBM10) P.157

Centering Sleeve