

OIL-FREE SLIDE UNITS FOR LOOSE CORE

—ADJUST TYPE—



■Features of Oil-free Slide Units for Loose Core

- Enables the inclined pin to slide smoothly when pushing out a loose core (including undercut) at an angle.

| Item | Parts Name | Material | Piece |
|------|---------------------|-------------------------------------|-------|
| ① | Guide Rail | S45C | 2 |
| ② | Inclined Pin Holder | | 1 |
| ③ | Slide Plate | High strength brass+Solid lubricant | 2 |
| ④ | Set Pin | SK5M | 1 |
| ⑤ | Lock Plate | SS400 | 2 |
| ⑥ | Hexagonal Bolt | SCM435 | 4 |
| ⑦ | Adjust Rod | S45C | 1 |
| ⑧ | Lock Nut | S45C | 1 |

C-SCKRM

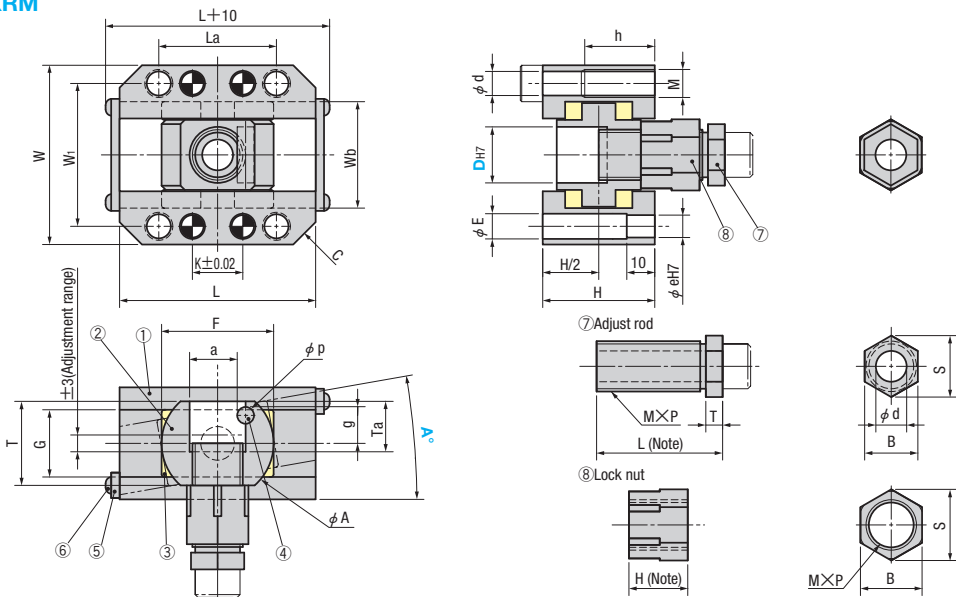

| W | W ₁ | L | K | L _a | W _b | C | d | M | h | e | E | H | T | G | F | A | p | a | g | T _a | Part No. | | Mounting angle of slide plate A° 1° Increments |
|-----|----------------|-----|----|----------------|----------------|----|------|-----|----|----|-----|----|----|----|----|----|---|----|----|----------------|----------|----|---|
| | | | | | | | | | | | | | | | | | | | | | Type | D | |
| 54 | 44 | 65 | 18 | 38 | 33 | 8 | 6.6 | M 8 | 20 | 6 | 6.6 | 35 | 24 | 20 | 40 | 30 | 6 | 13 | 10 | 15 | C-SCKRM | 16 | 0~20° |
| 64 | 51 | 70 | | 42 | 38 | | | | | | | | | | | | | | | | | 40 | |
| 70 | 58 | 80 | 20 | 45 | 45 | 10 | 8.6 | M10 | 25 | 8 | 9 | 44 | 35 | 26 | 45 | 45 | 8 | 22 | 14 | 20.5 | 25 | | |
| 78 | 64 | 100 | 40 | 70 | 51 | 54 | | | | | | | | | | | | | | | 38 | 30 | |
| 92 | 75 | 115 | 50 | 85 | 66 | 8 | 10.6 | M12 | 30 | 10 | 11 | 60 | 40 | 34 | 70 | 55 | 8 | 31 | 15 | 23 | 30 | | |
| 100 | 82 | 125 | | | | | | | | | | | | | | | | | | | 58 | 51 | |
| | | | | | | | | | | | | | | | | | | | | | | 40 | |

■Dimension H (11° ≤ A° ≤ 20°)

| D | 11°~15° | 16°~20° | M×P | ⑦ Adjust rod | | | | ⑧ Lock nut | | | |
|----|---------|---------|---------|--------------|---|----|------|------------|------------|------|----|
| | | | | L (Note) | T | d | S | B | H (Note) | S | B |
| 16 | 41 | 48 | M14×1.5 | 42(50) | 6 | 9 | 16.2 | 14 | 21(28) | 19.6 | 17 |
| 20 | 47 | 55 | M18×1.5 | 45(54) | | | | | | | |
| 25 | 52 | 61 | M22×1.5 | 49(59) | 7 | 13 | 25.4 | 27 | 21.5(30.5) | 31.2 | 27 |
| 30 | 62 | 72 | M27×1.5 | 54(64) | | | | | | | |
| 35 | 70 | 82 | M30×1.5 | 58(68) | 7 | 17 | 37 | 32 | 28(38) | 41.6 | 36 |
| 40 | 78 | 90 | M36×1.5 | 60.5(70.5) | | | | | | | |

☝(Note) The values in () in the L and H columns are the values when A is more than 11°.



Order

Part No.

A°

C-SCKRM16 - 10



Days to Ship

12 Days



Price

Order / Quote:

WOS: <https://in.misumi-ec.com/>

TEL:+91-124-468-8800 E-mail:cs@misumi.co.in

